

MINIMUM CLEARANCE FOR PROPER OPERATION IS 36 INCHES FROM THE WALLS, SHRUBBERY, FENCES, ETC. MINIMUM CLEARANCE BETWEEN ADJACENT UNITS IS 72 INCHES.

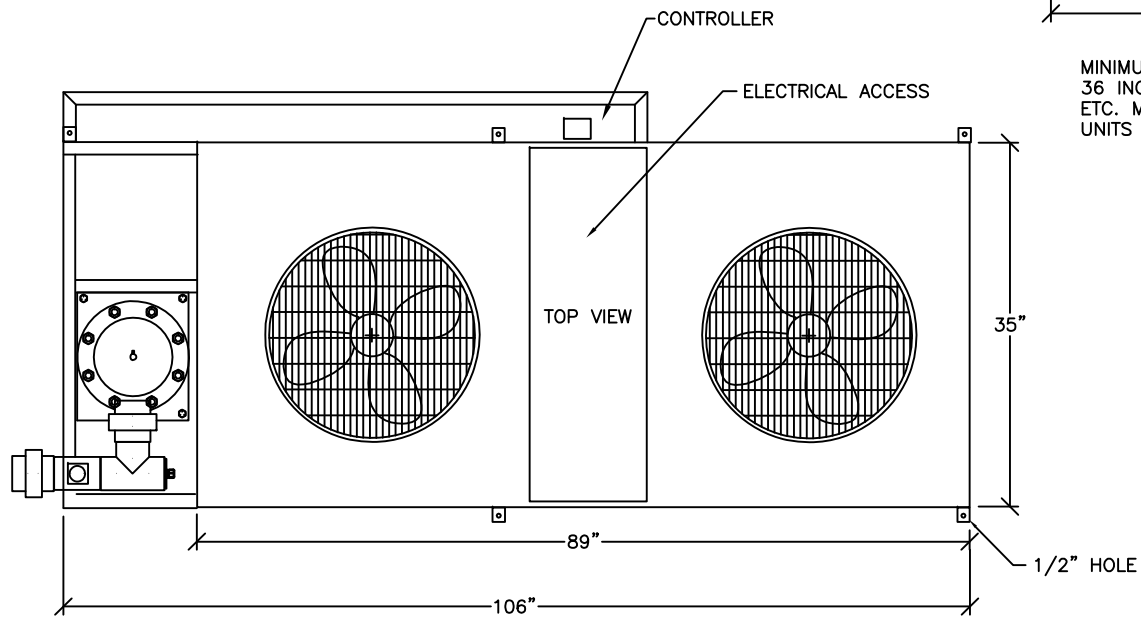

SPECIFICATIONS:

- MODEL NO: _____ HP-15
- HP: _____ 15
- VOLTS / PH / Hz _____ 208 - 240 / 3 / 60
- VOLTAGE MIN-MAX _____ 197 - 253
- TOTAL UNIT AMPS _____ 67.2
- MIN. CIRCUIT AMP. _____ 90
- MIN. FUSE SIZE _____ 80
- MAX. FUSE _____ 90
- MAX. BTUH OUTPUT _____ 180,000
- MIN - MAX WATER FLOW _____ 120 / 180 GPM
- FANS CFM EA _____ 5500
- SHIPPING WEIGHT _____ 1400 LBS
- REFRIGERANT TYPE _____ R-22 30 LBS.

aqualogic Aqua Logic, Inc.
8268 Clairemont Mesa Blvd. Suite 302
San Diego, CA 92111

TITLE: HP-15 230V 3φ HEAT PUMP